

# Circuit Diagram of Power Supply & Charging (Edit 64)

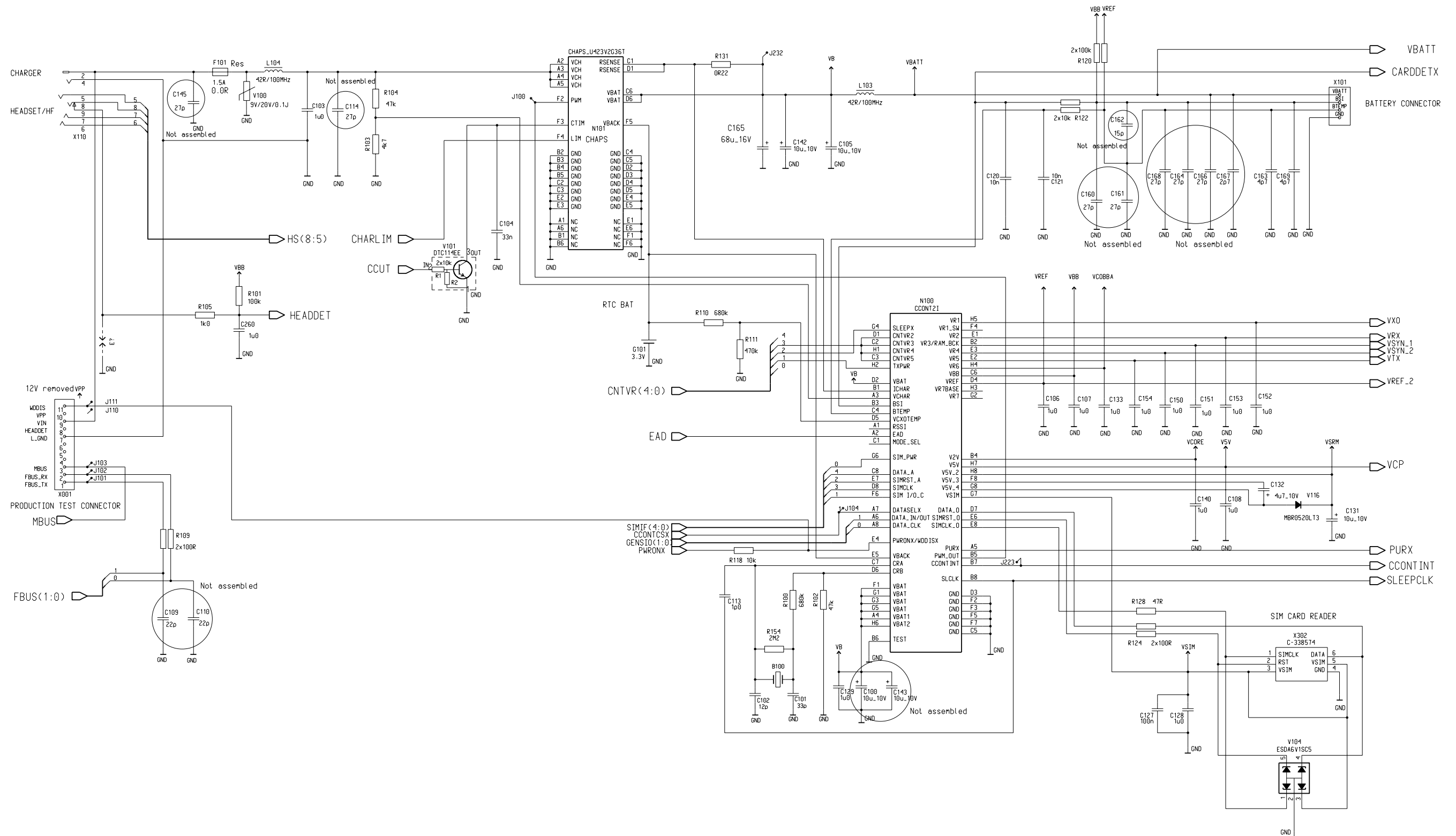

# Circuit Diagram of CPU Block (45)

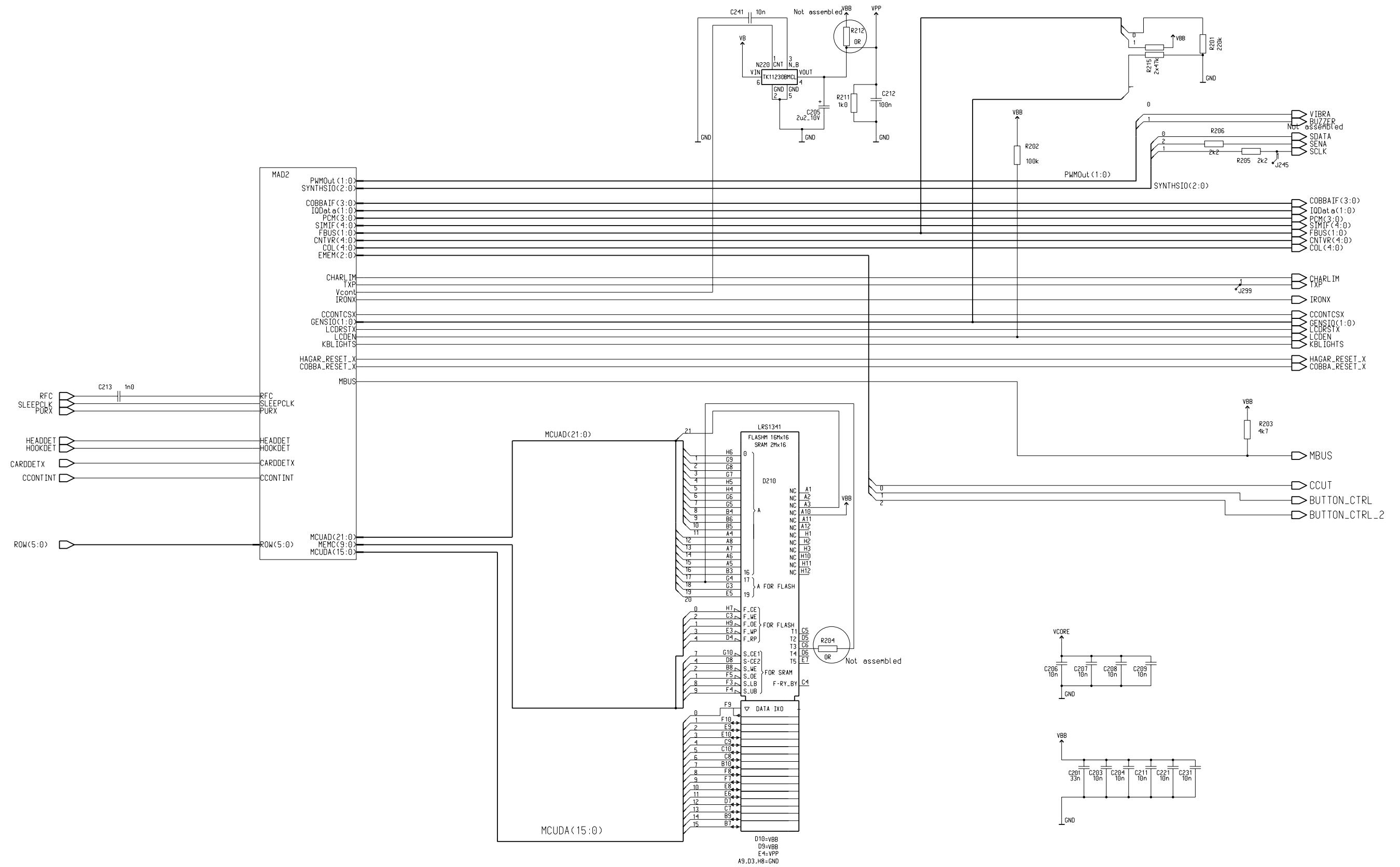

Connection between RF and Baseband modules (Edit 37)

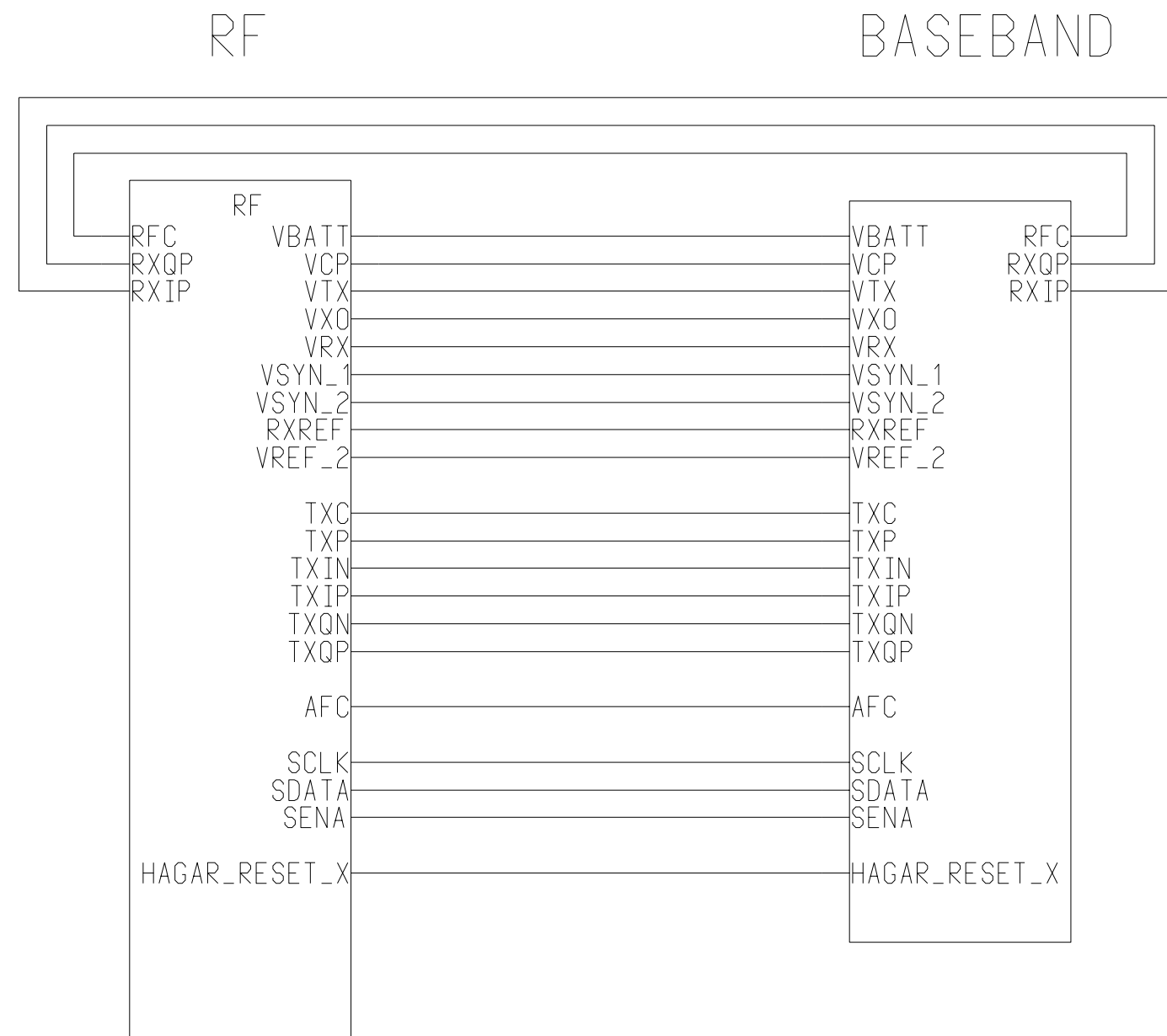

# Baseband Block Interconnections (Edit 40)

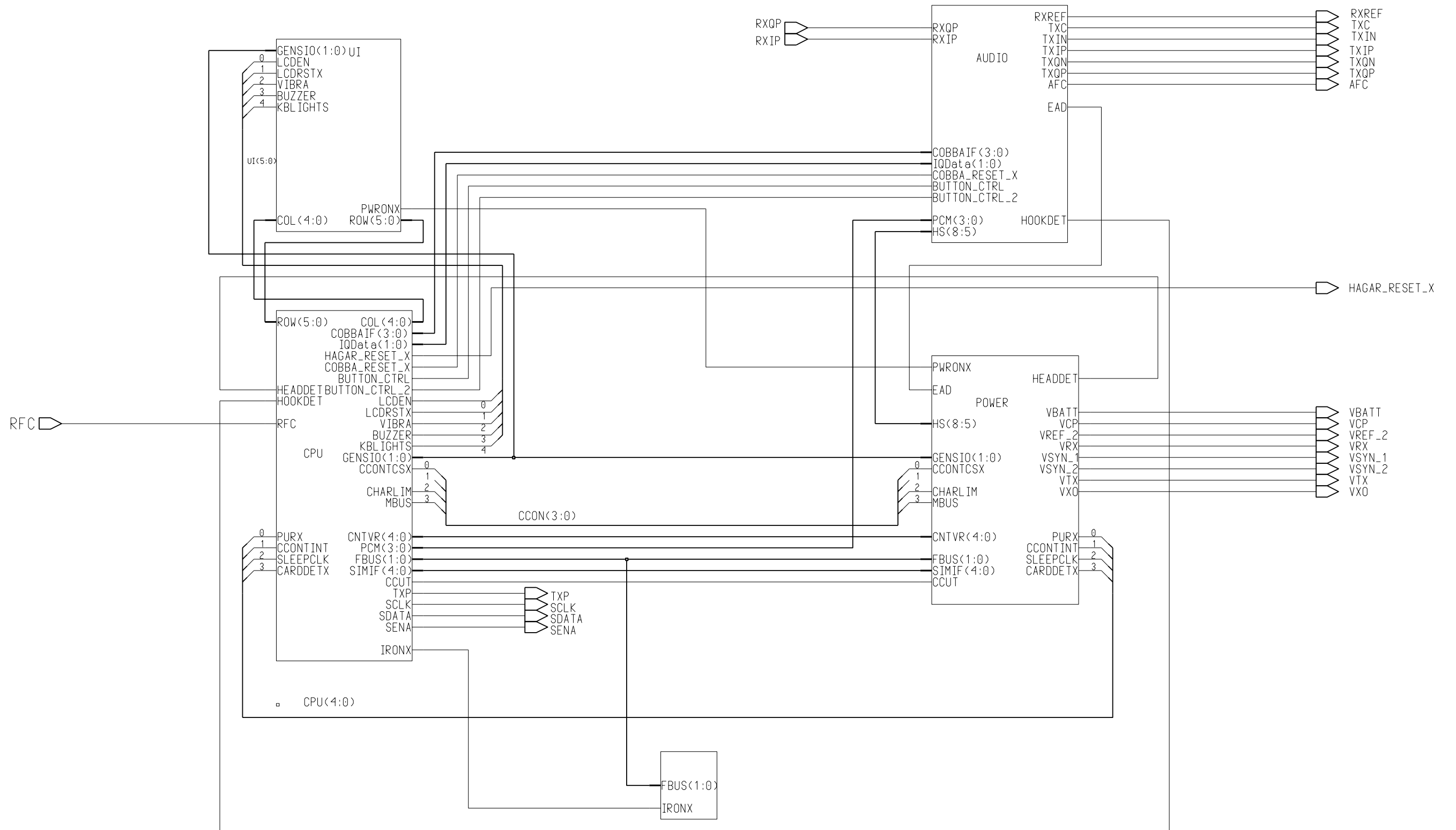



# Circuit Diagram of RF Module (Edit 132)

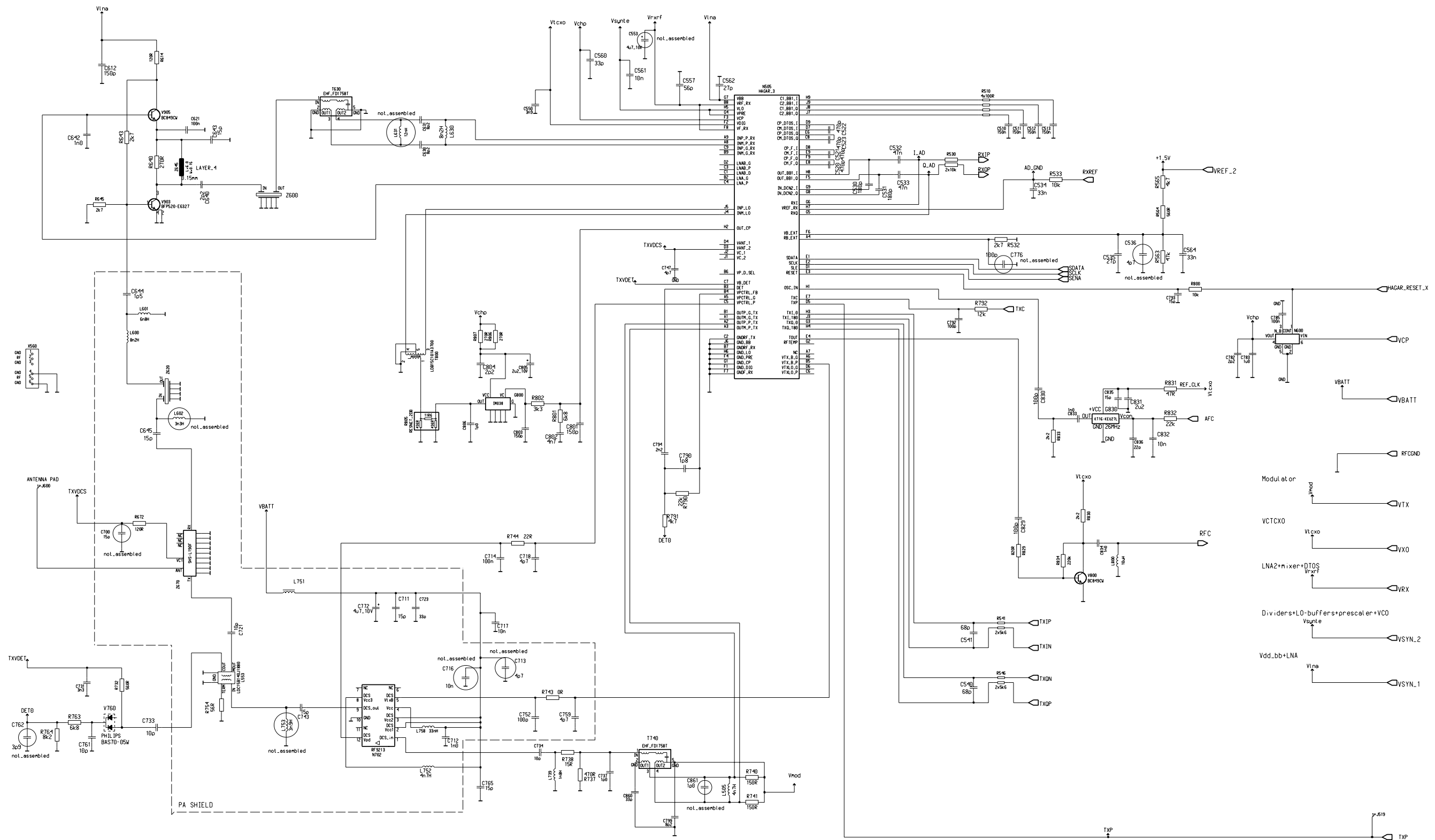

# Circuit Diagram of UIF (Edit 36)

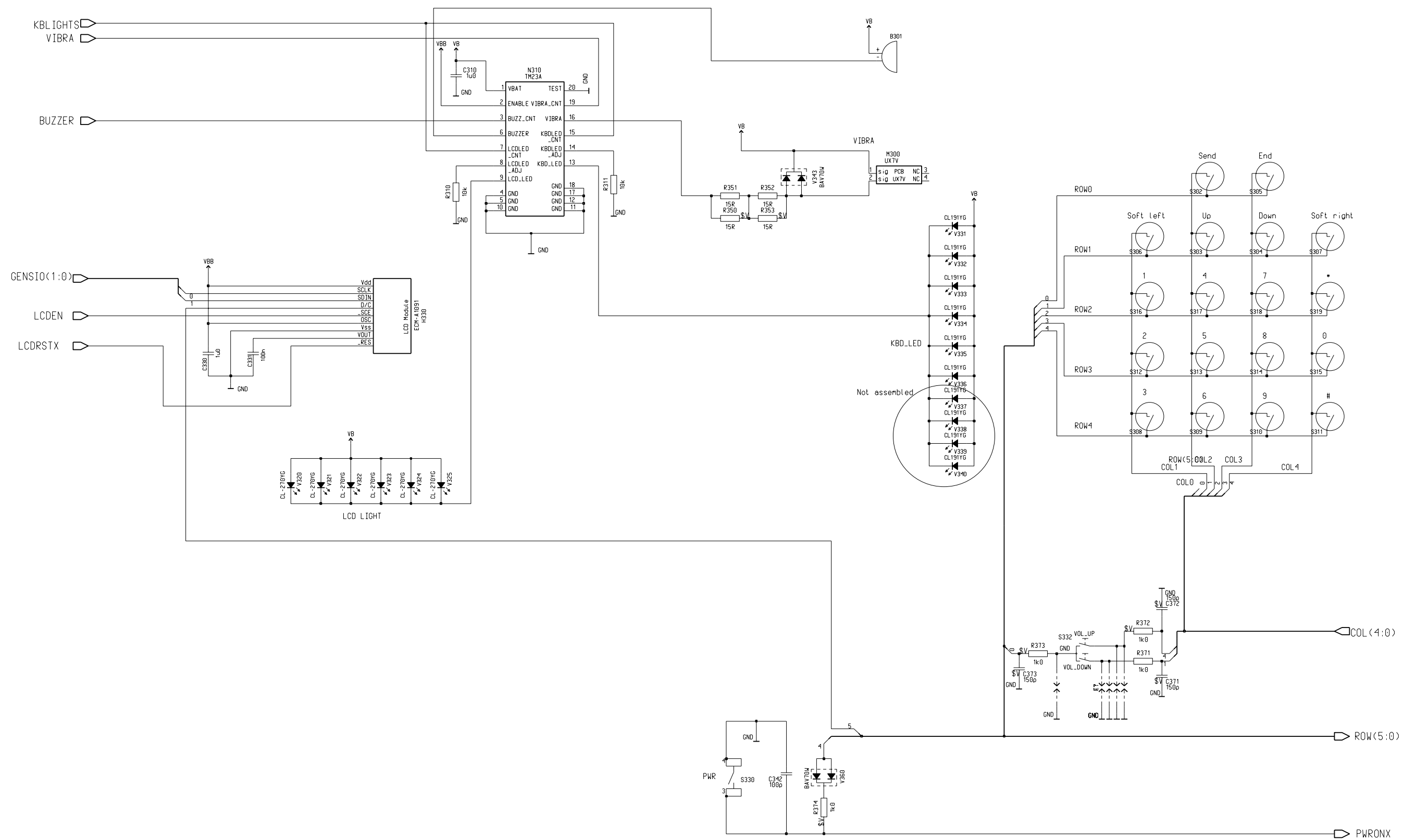







### Layout Diagram of RB9 - TOP (Version 05)

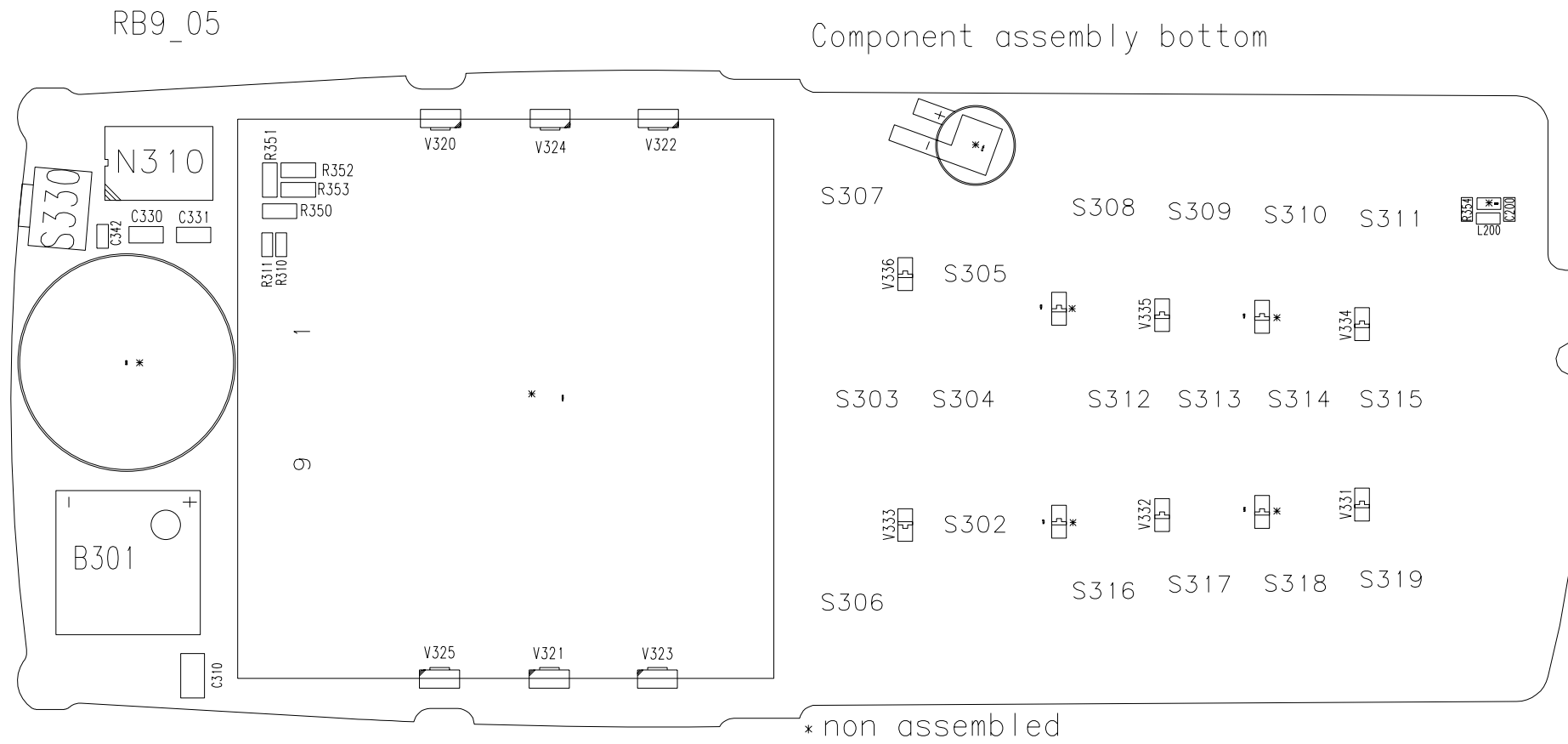

### Layout Diagram of RB9 - BOTTOM (Version 05)

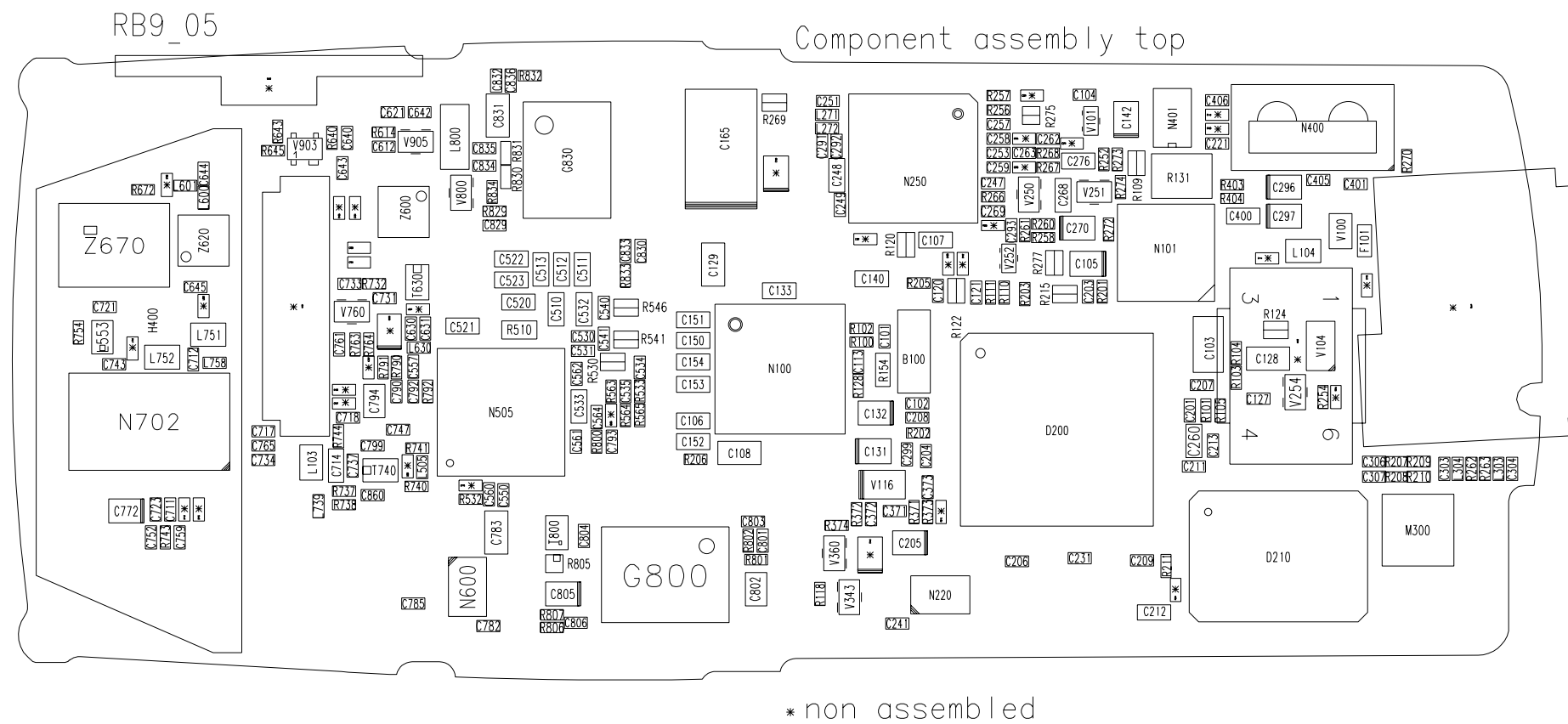

# Test Points for RB9- TOP

RB9\_05

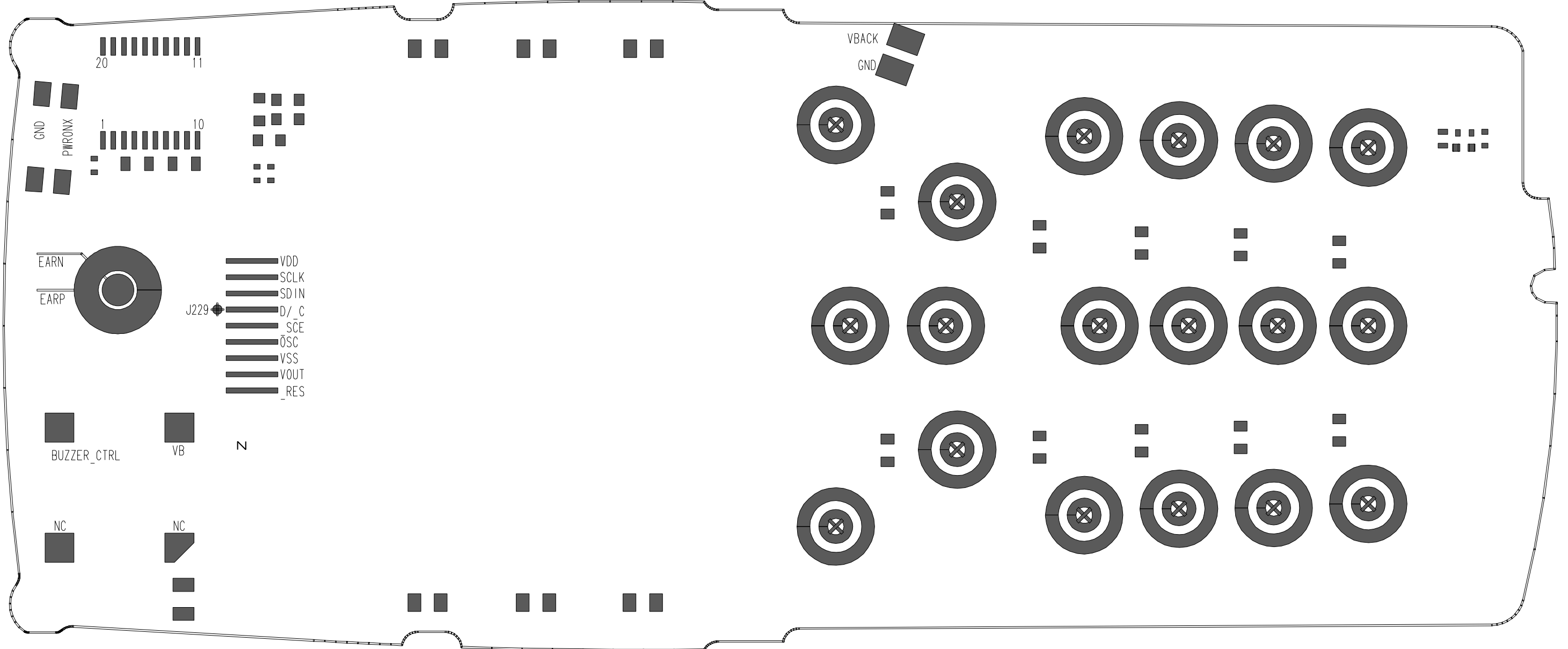





# RF Testpoints for RB9

RB9\_05

